

STANDARD EQUIPMENT

- Automatic outriggers levelling with electronic inclinometer
- Outrigger pads (Ø 200 mm)
- Emergency hand pump
- Cylinder holding valve
- Electronic hour meter
- Momentum device
- Load cell
- Hydraulic Jib
- Rubber tracks
- Hydraulically adjustable tracks width
- Double speed traction
- Air / Water outlet in the platform
- 230V - 16 A outlet in the platform
- Wireless radio-control box

PETROL/DIESEL EQUIPMENT

- Petrol engine Honda iGX800 - 18 kW HP 3600 rpm
- Diesel engine Yanmar 3TNV70 - 17 kW 3600 rpm
- 230V - 16 A electro-pump for indoor use

LITHIUM EQUIPMENT

- Lithium batteries 48V / 160Ah
- Electric motor 48V / 10 kW AC low voltage

OPTIONALS

- Non-marking rubber tracks
- Working light in the platform
- Aluminium basket (0.90 x 0.75 x 1.10 m)
- Kit IMERVIEW

PETROL/DIESEL OPTIONALS

- 12V emergency electro-pump

LITHIUM OPTIONALS

- 48V emergency electro-pump



BENEFITS

- ✓ Double articulation boom with active jib for a high operability in all construction site conditions.
- ✓ Variable stabilization area for greater flexibility of use in various work situations.
- ✓ Hydraulically adjustable tracks width: more stability and traction to move around the building site or rough terrain.
- ✓ State-of-the-art removable control panel: fast and versatile use of the machine.
- ✓ Proportional and simultaneous electro-hydraulic controls: efficiency and safety for operators.
- ✓ Automatic outriggers levelling: maximum easiness of use and safety.
- ✓ Permanent weight control device for improved safety and performance.
- ✓ Turret slewing 360° (not continuous): outstanding aerial accessibility in any work situation.
- ✓ Basket rotation ± 62°: complete placement on working site in any condition.
- ✓ Engine guarded for safety and working protection.
- ✓ Aluminium basket 1.40 x 0.70 x 1.10 m.
- ✓ Lithium batteries and AC electric motor for high performance (IM R 23 DA Lithium).
- ✓ Possibility to operate from the power network and simultaneously charge the battery (IM R 23 DA Lithium).

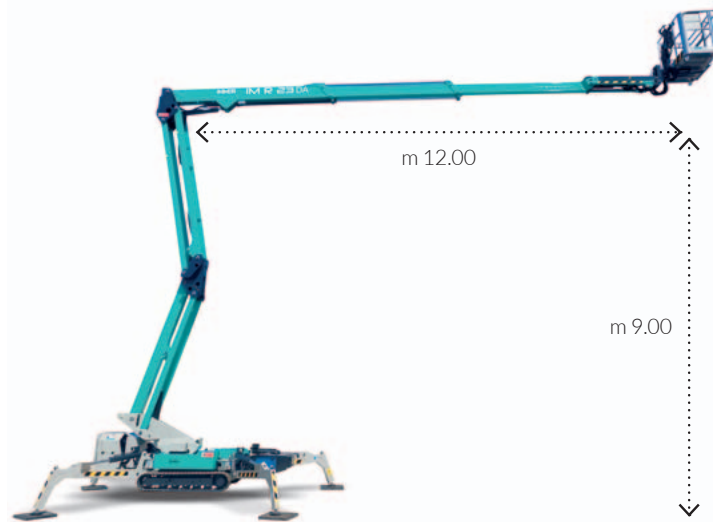

Extreme outreach of 12 m (with 140 kg) by 9 m of articulation height.

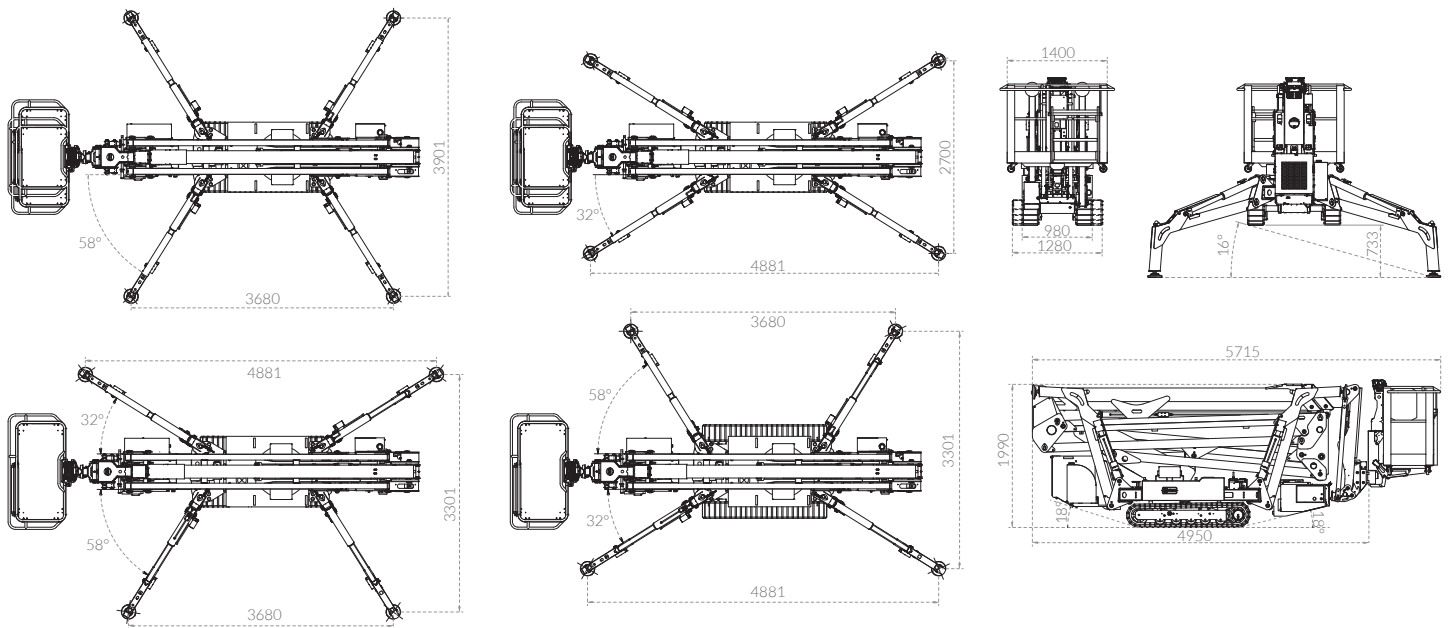

		IMR 23 DA	IMR 23 DA Lithium
Working height	m	22.85	22.85
Platform height	m	20.85	20.85
Side outreach (outrigger footprint standard)	m/kg	10.6 / 230 - 12 / 140	10.6 / 230 - 12 / 140
Side outreach (outrigger footprint narrow)	m/kg	7.3 / 230 - 8.6 / 140	7.3 / 230 - 8.6 / 140
Up & Over	m	9	9
Turret slewing	(°)	360 (not continuous)	360 (not continuous)
Basket dimensions	m	1.40 x 0.70 x 1.10	1.40 x 0.70 x 1.10
Overall outrigger footprint standard (narrow)	m	3.68 x 3.90 (4.88 x 2.70)	3.68 x 3.90 (4.88 x 2.70)
Max driving speed	km/h	2.8	1.5
Gradeability	%	32	32
Max load capacity	kg	230	230
Electric motor	V / kW	230 / 2.2	48 / 10 AC low voltage
Petrol engine Honda iGX800	kW/rpm	18 / 3600	-
Diesel engine Yanmar 3TNV70	kW/rpm	17 / 3600	-
Lithium batteries	V / Ah	-	48/160
Lithium batteries charger	V / A	-	48/50
Transport length (without basket)	m	5.71 (4.95)	5.71 (4.95)
Transport width (with extended tracks)	m	0.98 (1.28)	0.98 (1.28)
Stowed height (with outrigger pads)	m	1.99 (2.10)	1.99 (2.10)
Total weight of the machine	kg	2990 (petrol) 3000 (diesel)	3000

